

XP31LR: Dimmer 40-1000VA ohms inductive

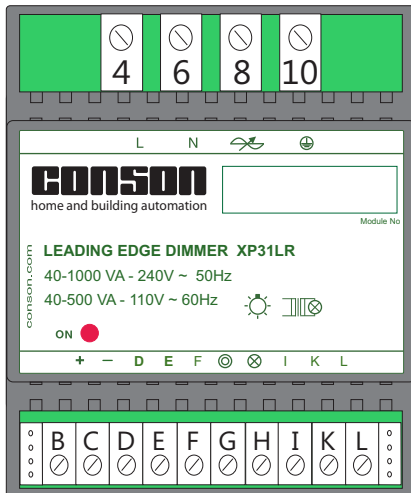

EAN-Nr.:5703513058845

The dimmer module XP31LR is an intelligent programmable dimmer to dim the ohms and inductive loads with a power of 40-1000 VA. The XP31LR regulates logarithmically and has a built-in soft-start, thermal security and reporting of an interruption of the neutral conductor. the dimmer has a direct impulse input. When using the data-bus, up to 99 programmed functions are performed for the realization of modes and this by using dimming actions by percent, up and down, time and fade functions and daylight management.

XP31CR: Dimmer 40-600 VA ohms capacitive

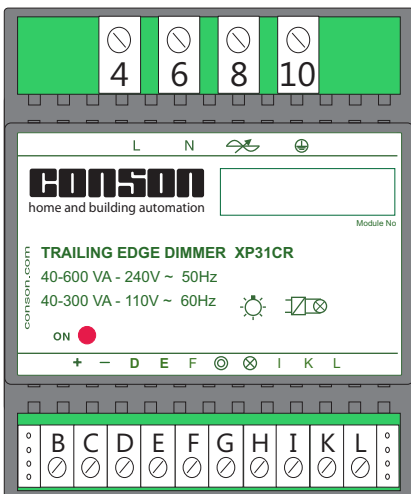

EAN-Nr.:5703513055288

The dimmer module XP31CR is an intelligent programmable dimmer to dim resistive and capacitive loads with a power of 40 - 600 VA. The XP31CR regulates logarithmically and has a built-in soft-start, thermal protection and reporting of neutral interruption. The dimmer has a direct impulse input. When using the data-bus, up to 99 programmed functions are performed for the realization of modes and this by using dimming actions by percent, up and down, time and fade functions and daylight management.

XP31U: Universele dimmer 40-1000VA resistive inductive capacitive

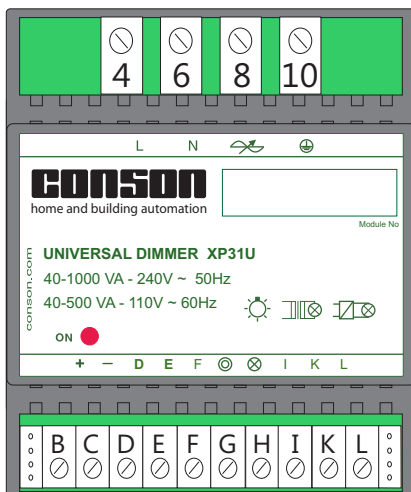

EAN-Nr.:5703513057749

(If not available, replaceable by XP31LR)

The dimmer module XP31U is an intelligent programmable universal dimmer to dim resistive, inductive and capacitive loads with a capacity of 40-1000 VA. The XP31U regulates logarithmically and has a built-in soft-start, thermal protection and mention of an interruption of the neutral conductor. The dimmer has a direct impulse input. When using the data-bus, up to 99 programmed functions are performed for the realization of modes, and this by using dimming action by percent, up and down, time and fade functions and daylight management.

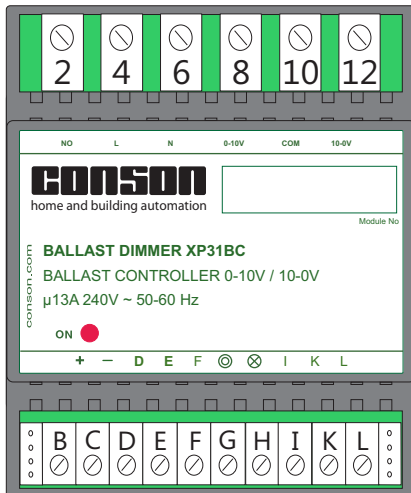
XP31BC: Ballast dimmer 0-10V/10-0V

EAN-Nr.:5703513055240

The dimmer XP31BC module is an intelligent programmable dimmer to dim HF-ballasts for fluorescent and PL lamps and others with a 0-10V/10-0V control signal. A relay 13A is provided in order to switch the power supply of the ballasts. The dimmer controls XP31BC regulates logarithmically and has a built-in soft-start. The dimmer has a direct pulse input. Upon the commissioning of the data-bus, up to 99 programmed functions are performed for the realization of the modes and this includes the dimming actions by percent, up and down, time and fade functions and daylight management.

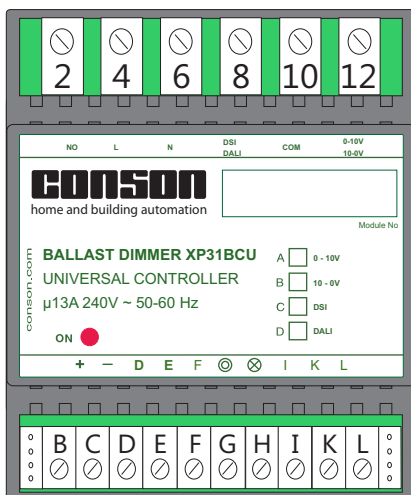
XP31BCU: Universal ballast dimmer 0-10V/10-0V Dali/DSI

EAN-Nr.:5703513055257

The dimmer XP 31 BCU module is an intelligent, universal and programmable dimmer to dim HF ballasts for fluorescent and PL lamps and others with various signals such as 0-10V/10-0V/Dali and DSI (Digital Addressable Lighting Interface) or DSI (Digital Serial Interface – a non-addressable digital control). A relay 13A is provided for switching the power supply of the ballast. The dimmer XP31BCU regulates logarithmically and has a built-in soft-start. The dimmer has a direct impulse input. Upon the commissioning of the data-bus, up to 99 programmed functions are performed for the realization of modes, and this includes dimming actions by percent, up and down, time and fade functions and daylight management. Through the ConTool software one can program the type of control signal. The XP31BCU is the ideal ballast-dimmer when one does not know in advance what type of ballast it will be.

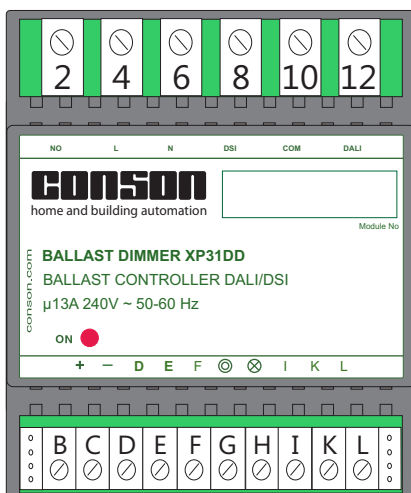
XP31DD: Ballast dimmer Dali en DSI

EAN-Nr.:5703513055387

The dimmer XP31DD module is an intelligent programmable dimmer to dim HF ballasts for fluorescent and PL lamps and others with this Dali (Digital Addressable Lighting Interface) or DSI (Digital Serial Interface - a non-addressable digital control). A relay of 13A is provided for switching the power supply of the ballast. The dimmer XP31DD regulates logarithmically and has a built-in soft-start. Upon the commissioning of the data-bus, up to 99 programmed functions are performed for the realization of modes, and this includes dimming actions by percent, up and down, time and fade functions and daylight management. Through the ConTool software one can program the type of control signal.

Main features

The dimmers XP31 have a microprocessor for progressive steering. Special features inter alia, soft-start, adjustable fade-in and fade-off times, thermal security, logarithmic arrangement, potentiometer-control, analog daylight-dependent control, slave control, security against neutral-break and a minimum and maximum setting without adjustment-potentiometers.

Softstart and fade-in en fade-uit

When switching on the dimmer, the output voltage goes from zero to the last used or desired level and this according to a certain amount of time defined in the firmware of the module. This working method prevents brutal interference on the mains when switched on and extends the life of the lamp. In addition, a timely limitation is ensured by a short-circuit during the breakage of the filament. The fade-in and fade-off times can be accessed via the bus and this with actions ranging from 5 seconds to 2 hours.

Thermal protection

This limits the temperature inside the module. The level of limitation is dependent on the type of dimmer. If this temperature is exceeded, the dimmer sends an SOS signal. Because of the SOS signal, the LED-dimmer flashes in rhythm of 3 x short and 3 x long. This signal is also present at the output of the LED-dimmer module. During the SOS signal, the output level is adjusted downwards. The reset is done by activating the impulse input of the dimmer for 20 seconds, or by removing the power supply voltage 24 VDC. This protocol can be different according to type of dimmer.

Protection against short-circuit

The dimmer of the CR and U are short-circuit proof. The power of these dimmers is controlled by the power mosfet-transistors. These are fast enough to switch the output switch.

Logarithmic control

The dimmers have a logarithmic regulation which ensures that, when being operated, an ergonomic feeling arises between the operation and the determination of the light variation.

Protection against neutral-break

A disconnected or interrupted neutral is indicated by the LED on the dimmer. This light flashes rhythmically, followed by a long pause. In this mode, the dimmer will not work. These security includes inter alia the following advantages: it must connect properly so that the filter network is functioning (interference suppression to the mains and vice versa) and it protects the component against overstrain (e.g. 380V instead of 230V). A neutral-break from the base means that there is a high tension in certain light grids on the load and thus cannot simply be transferred to the load. More so, Conson has deliberately opted for sustainable control components that can withstand 1000V.

Power loss of a dimmer

The choice and quality of the components contribute to a minimal power loss of 1% to the load. Thus 10W for XP31LR with a full load of 1000VA, 6W for XP31CR with a full load of 600VA and 10W for XP31U with a full load of 1000VA. This loss of power must always be taken into account. This generates heat dissipation in the enclosure and can be removed through natural ventilation.

Important remark:

Always insert the dimmers at the bottom of the enclosure. Thus, this cannot be heated by other components.

Potentiometer control

All dimmers type XP31 have a potentiometer input. This input is also a 1-10 VDC input. Between 0.75 and 10 VDC dimmer regulates itself from minimum to maximum and at 0.5 VDC it turns off.

Automatic daylight-dependent level

All dimmers type XP31 have a daylight level and cooperation with a light sensor. Thus, it is possible to obtain a constant light-level at the workplace. This function can also be reversed. This is useful for example, to extend the day at bird farms or for the enlightening of advertising panels.

Slave function

More dimmers of the type XP31 can be connected in parallel to the control level. Useful in banquet rooms with movable walls. When all the walls are pulled back, all buttons work similarly. Can also be used to control three-phase dimmable loads.

Minimum and maximum level

Het minimum en maximum niveau is instelbaar via de rechtstreekse ingang of via de software Contool. Het minimum instellen is bijzonder nuttig wanneer de lichtbron verdoken zit in zijn armatuur (men ziet de gloeidraad of andere niet, b.v. uplighters).

The minimum and maximum level is adjustable via the direct input or via the ConTool software. Setting the minimum is particularly useful when the light source is hidden in its armature (one cannot see the filament or others, e.g. uplighters). May also be useful for the minimum speed of fans. Through the ConTool software, one can decide that the first dimmer is directed towards the maximum, such that the engine get to its speed. The maximum is useful in terms of energy savings. The difference between 95% and 100%, is hardly visible.

Connections high power of the XP31LR/CR/U/BC/BCU/DD Connecting the control line of the XP31BC/BCU/DD

Example with a XP31LR Power-regulation

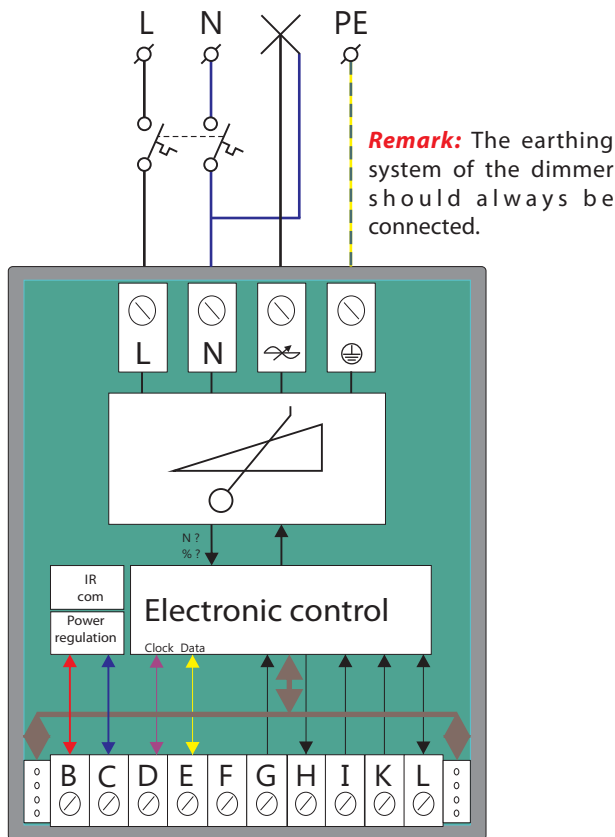

Example with a XP31BC 0-10VDC regulation

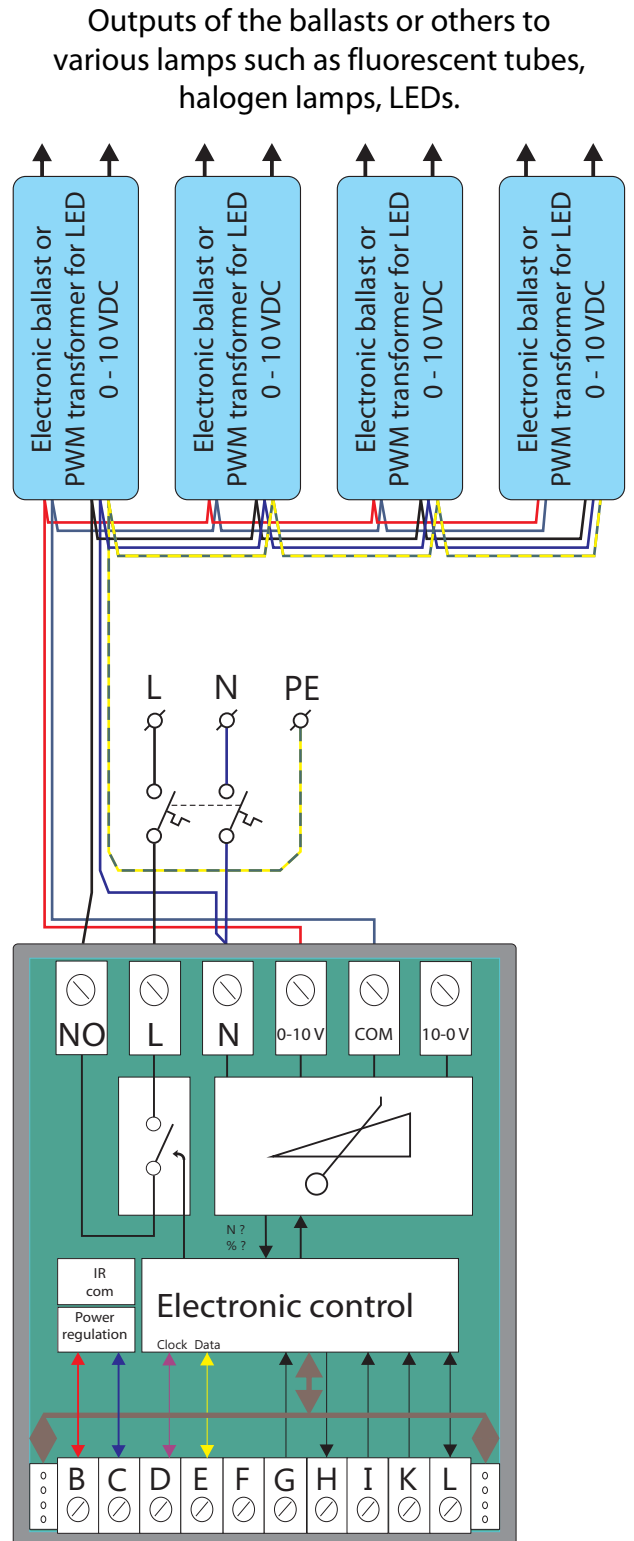

Important information:

The dimmer XP31BCU is a universal ballast controller. This type of ballast controller is particularly useful when it is not known in advance which load will be operated.

Through the ConTool software, the following modes of output signals are selectable: analog 0-10 V or 10-0 VDC or digital Dali or DSI.

Be careful: the analog outputs are located between terminals 5 and 6, the digital outputs between terminals 5 and 4. The terminal 5 is the common or the minus.

Connections high power side of the XP31LR/CR/U/BC/BCU/DD Connecting the control line of the XP31BC/BCU/DD

Example with a XP31DD

Dali regulation

Outputs of the ballasts or others to various lamps such as fluorescent tubes, halogen lamps, LEDs.

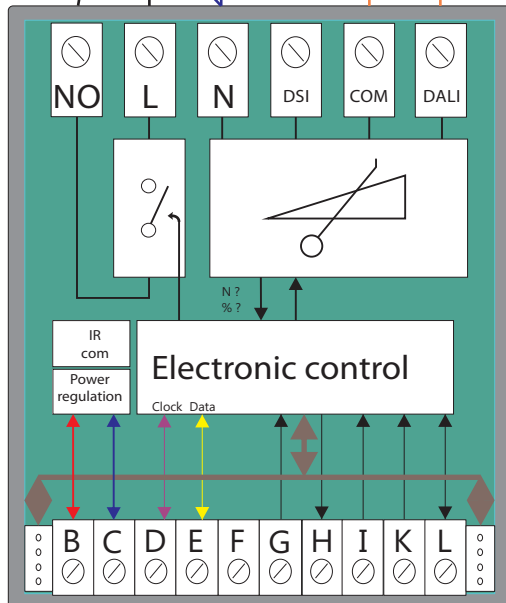
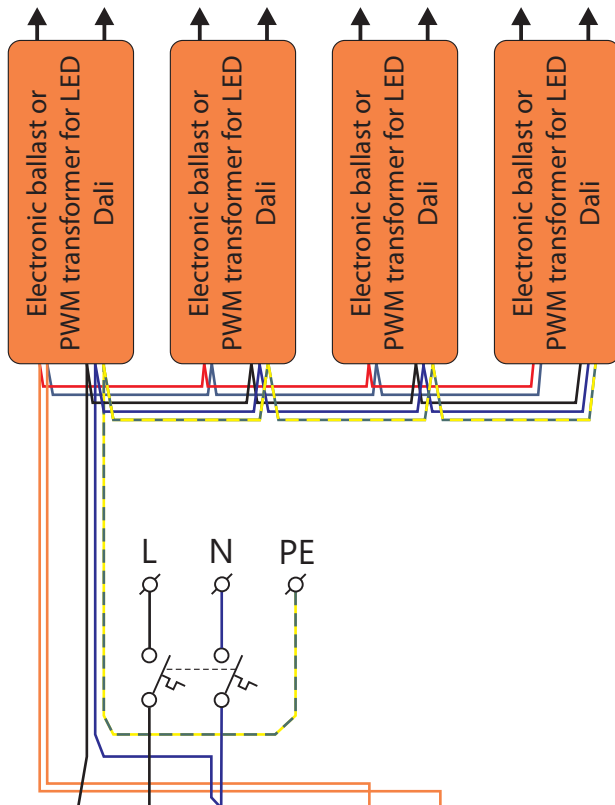

Example with a XP31BCU

DSI regulation

Outputs of the ballasts or others to various lamps such as fluorescent tubes, halogen lamps, LEDs.

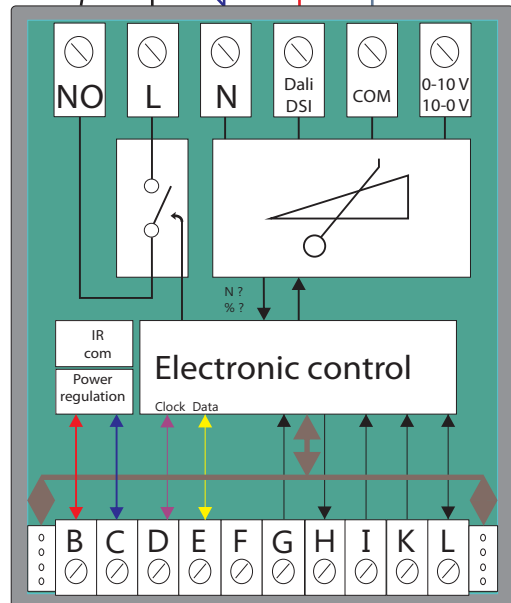
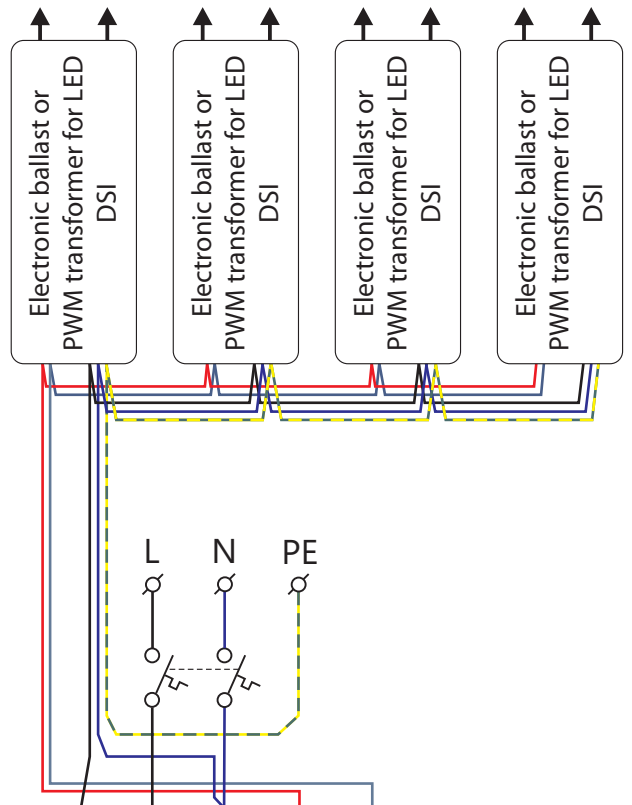

Low power connections of dimmers XP31LR/CR/U/BC/BCU/DD

Control via the direct inputs

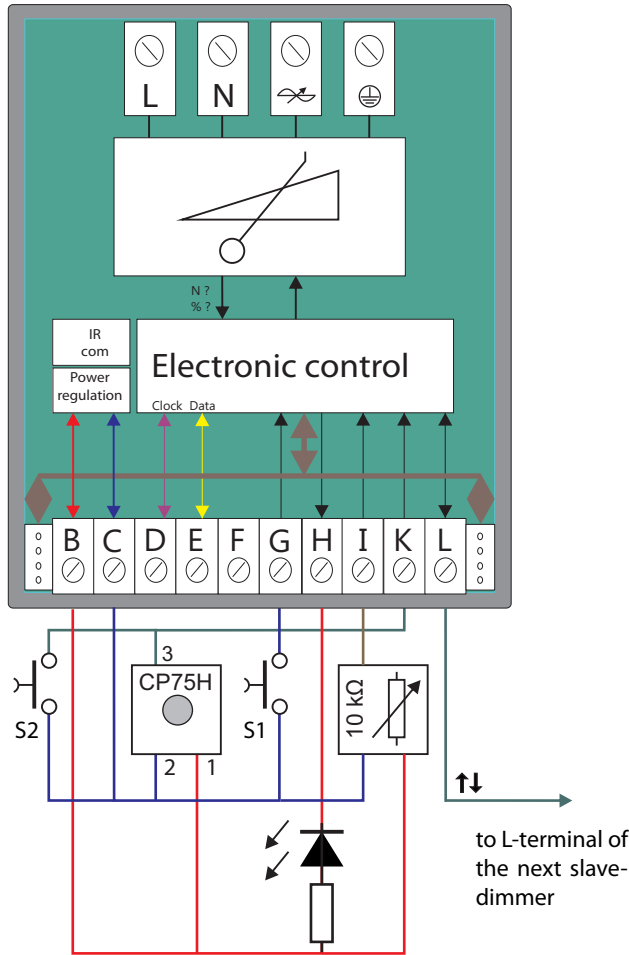

S1 push-button dimming and on / off
S2 push-button automatic daylight level on / off

Note: The potentiometer-input (terminal I) is also a 1 -10 VDC input. Between 0.75 V and 10 V control from minimum to maximum at 0.5V dimmer off.

Setting minimum and maximum

By connecting the push-button S1 to the direct impulse input of the dimmer, it is possible to set the minimum and maximum light level. Following method: Keep pressing the push-button S1 when dimming downwards to the zero-level. Continue pressing the pushbutton until the dimmer naturally goes to a 100% light level (about 20 s). Then, while dimming, set the maximum light level. When the maximum level is set, give a short impulse and the light goes out. Press the button again and set the minimum light level. Then, again, give a short impulse, the light goes out. Again, give an impulse, the light goes on in its set minimum. After 10 seconds the light goes out, the dimmer has its minimum and maximum stored.

Control by the Consonbus

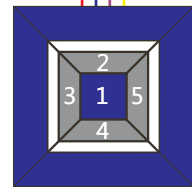
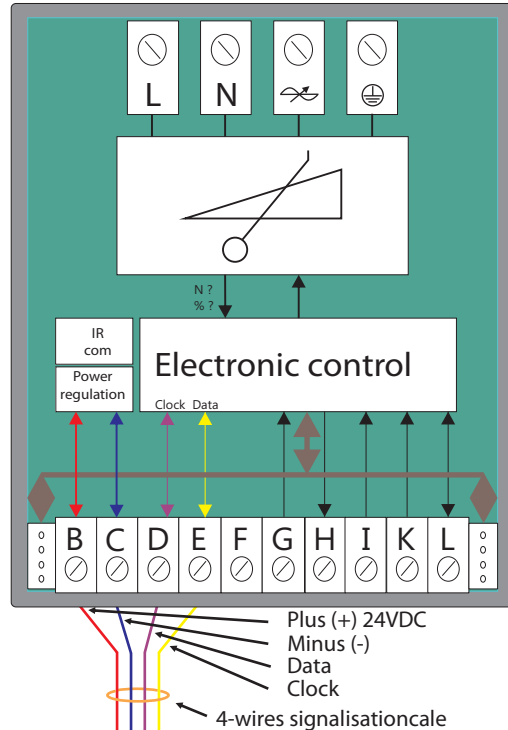

Sesam bus push-button in Hall

1. Welcome
2. Light Hall
3. Light WC
4. All off
5. Light Garden

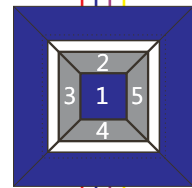

Sesam bus push-button 1 in Living

1. All lights living on/off
2. Dimming central light
3. Dimming wall lighting left side
4. All lights living fade slowly out
5. Dimming wall lighting right side

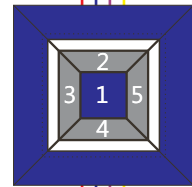

Sesam bus push-button 2 in Living

1. Light scene visit
2. Central light 95%
3. Scene look TV
4. All lights living fade slowly out
5. All wall lighting at 50%

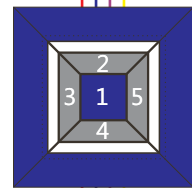

Sesam bus push-button in Kitchen

1. Central light on/off and at 50%
2. Light kitchen countertops on/off
3. Outside rear light on/off
4. Light kitchen off after 15 sec
5. Wall lighting on/off

Programming XP31 in the Concept 2000 Xp

Open ConTool software - add a floor plan - choose tab "Design state" - choose tab "Sensors/actors" (1) - Place the following components on the floor plan: select at the symbol "Lamp" (2) an actor XP31LR for the dining area and an actor XP31LR for the sitting area - select at the symbol "push-buttons" (3) a sesame push-button XP2506. Select the "Programming state"-tab (4) - select the XP2506 on the floor plan - it will appear in the right cameo.

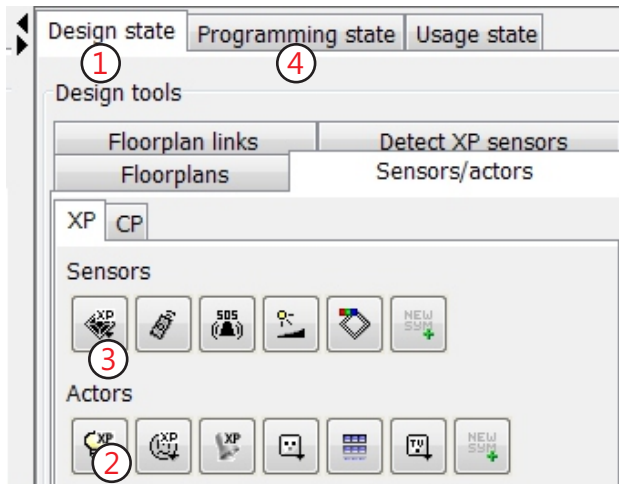

Specify a location for example, living room (5). Select the center push-button (it changes color from white to purple = active key) and write its function in the corresponding box: e.g. living room lights on / off 80% (6). At the bottom of the push-button panel, the programming method shows up automatically for the XP2506 sensor.

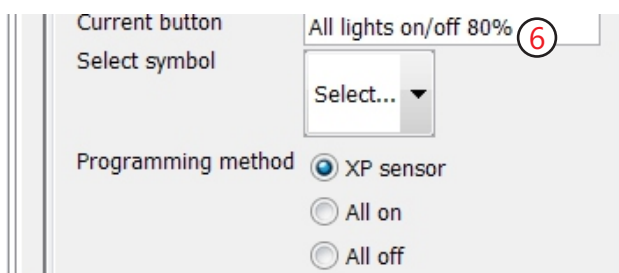
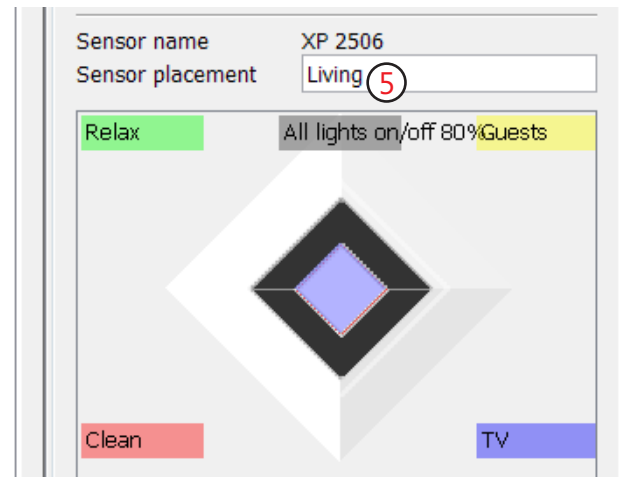

Click on the lamp of the dining area located on the floor plan. The "Functions for actor" "Circuit XP31LR" window opens. Change the actor-name (7) into the name "Dining area". Choose within the drop down menu (8) the action "Auxiliary relay" (Help function) and click "Add". Then choose the action "Adjust light level" and select 80% and click "Add". Click "OK" to exit. Click on the lamp of the living saloon located on the floor plan. The "Functions for actor Circuit XP31LR" window opens. Change the actor-name into the name "Sitting area". Add the actions similar to the light of the dining area and press OK.

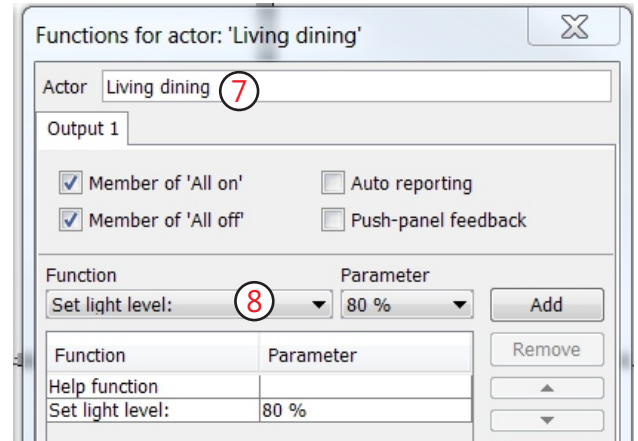

Select on the floor plan the sesame push-button XP2506, right click and select "Module setup". The "Special programming XP2506" window opens. Place a check marker for channel 1 (9) on the line "Group on/off". Go to the front tab "Control box" and click "Upload". The data are sent to the two dimmers XP31LR.

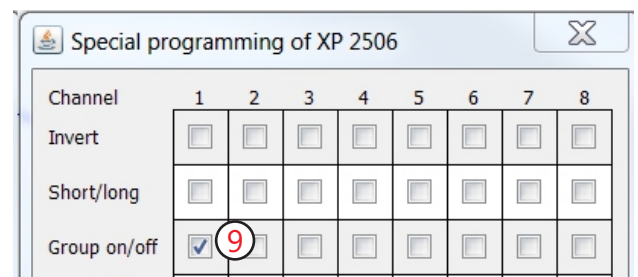

Click again on the front tab "Floor Plan" and select in the right cameo "User's interface". Click in the floor plan on the XP2506. The center button is activated to operate and the lights go on at a light level of 80%, press again and the lights go out. Now only the sesame push-button needs to be activated. This can be done in different ways. Either by directly filling in the serial number into the "Special programming XP2506" window, or via "Design" - tab "Insert XP sensors" - drag XP2506 from the list to the XP2506 on the floor plan and allow the serial number to copy.

The above method of programming is reflexive for all actors and sensors of the Concept 2000 Xp

The various actions

- Impulse** When pressing and pressing again, the actor goes on/off.
- Impuls + x-time** When pressing and pressing again, the actor goes on/off. By non-pressing again the actor goes out after x-time.
- On** On means actor on.
- On + x-time** On with a x-time means actor on for x-time.
- Off** Off means actor off.
- Uit + x-tijd** Off with a x-time means actor off after x-time.
- Block** Blocking means when a certain actor is blocked by a specific channel of a link, that as long as this channel is active, the actor cannot be operated. Thus, for example, locking certain push-buttons on alarm.
- Auxiliary relay** Auxiliary relay means when pressing a push-button (or door contact) that the actor goes on and goes off when unloading the actor.
- Auxiliary relay + next line x-time** See groups on/off description XP20.
- On after + next line for x-time** On after x-time means actor on for x-time.
- Light up/down** Sending the light level upwards with a certain %.
Sending the light level downwards.
- Light level up (%) down (%)** Sending the light level upwards with a certain %. Sending the light level downwards with a certain %.
- Set light level at x - %** Set the light level on a certain percentage.
- Set fade-time** Set fade-time in x-time (from 0.5 sec until 120 min).
- Set controle method** Choice between potentiometer, daylight-dependent or invert daylight-dependent.
- On after** Start after x-time (from 0.5 sec until 120 min).
- Random timer** Will be discussed in a later edition.

Programming special functions

To Fade

It is possible to regulate the light level to slowly to move up or down over time, this to a certain percentage or completely off. Next working method: Choose a push-button that has to perform the function. Click on the circle of light that it must perform. The actor window opens. Select the action "Adjust light level": (1) choose parameter e.g. 95% (2) and click "Add" (3). Then select "Set fade time" and choose the parameter 10 min, resulting in (4), click on "Add" (3) and close with "OK" (5).

Functions for actor: 'Living saloon'

Actor: Living saloon

Output 1

Member of 'All on' Auto reporting
 Member of 'All off' Push-panel feedback

Function: Toggle Parameter: 0 sec [Add] [Remove]

Function	Parameter
Set light level:	95 %
Set fade time:	10 min

[OK]

To fade downwards, take another push-button, and perform the same routine, but then to a level of light that is smaller, for example, 20% (6). To fade downwards and then completely off, add an action line Off (time): 10 min (7). **Remark:** The fade-time is the time to go from 0% to 100%. When the dimmer is set at 50% and one asks to go up to 100%, dimmer at 50% to 100% and asks to go, then the duration of the fade-time only is one half.

Functions for actor: 'Living saloon'

Actor: Living saloon

Output 1

Member of 'All on' Auto reporting
 Member of 'All off' Push-panel feedback

Function: Switch off (time): 10 min [Add] [Remove]

Function	Parameter
Set light level:	20 %
Set fade time:	10 min
Switch off (time):	10 min

[OK]

The different actions

Daylight depended light control

Will be discussed in a later edition.

Technical data

XP31 LR/CR/U/BC/BCU/DD

High power

Power supply	110/230VAC 50/60Hz
Minimum and maximum load	
XP31LR	40 - 1000VA
XP31CR	0 - 600VA
XP31U	40 - 1000VA
Own loss	< 1%
Rise time (soft start)	500 ms
Off time	750 ms
Fuse that has to be used	upto 10 A

Low power

Current decrease at rest at 24VDC	10,8 mA
Consumption at rest at 24VDC	0,026W
Input current of all inputs	0,5 mA
Impulse time all inputs	between 50-300 msec

Mechanical data

Montage	Din-rail DIN46277
Measurements	85x70x72 mm